

DATA QUALITY AND GROUNDING

BY MARCUS O. DURHAM
& ROBERT A. DURHAM



MOST INDUSTRIAL, COMMERCIAL, AND EDUCATIONAL FACILITIES depend heavily on telecommunications, data, and computer networks. In many petrochemical installations, the functions of all three types of facilities are combined into one location. These

facilities often experience problems with signal quality and noise on communication lines because of the proximity of high-speed, low-level signals to higher power lines. Additionally, electrical safety and various code issues must be addressed. Topics such as multiple ground systems, connections to ground, potential difference, circulating currents, and wiring methods are discussed. Eleven different systems must be bonded together. Three areas specific to networks require special attention. These are equipment bonding, isolated earth ground, and isolated power systems. Finally, cathodic protection systems have a unique impact on grounding systems.

Background

Proper application of grounding systems, signal isolation, electrical safety, and power quality are key to the successful installation and operation of any electrical and data system, whether in a building or a plant [1]–[4]. These topics are discussed based on an installation in a combined use facility consisting of process, laboratory, training, and administration areas. The variety of applications covers most industrial facilities. Not surprisingly, it is found that the electrical grounding issues are universal [5], [6].

Engineers responsible for connections to the utility grid, external communications, and internal computer networks all make installations in accordance with standard plans and

Considerations
in a mixed-use
facility

specs. These designs are appropriate for the particular system but may not consider other networks in the facility. This parochial design philosophy creates problems with the sensitive signals of computer networks.

Computer and communications networks operate at much lower levels and higher frequencies than power systems or analog telephone systems. As a result, the equipment is more susceptible to unbalances and transient disturbances. Very close attention to the details is necessary for successful, long-term operation of the equipment. Traditional electrical installations are adequate for supplying power and personnel safety. However, several issues arise that must be addressed in a mixed-use facility.

The initial thought in many grounding applications is simply to connect everything together at every chance. Unfortunately, that philosophy introduces many safety and operational problems including potential differences, circulating currents, and noise interference.

Grounding Terms

Although all grounds are eventually connected to the soil, five different categories of earthing systems can be defined. Understanding the relationship of these systems to electrical parameters will aid in designing an effective ground network.

- 1) *Neutral (grounded)*: Neutral, or grounded, conductors provide a common reference for power. This conductor carries current during normal operation. It is also connected at a single point to the ground circuit. The grounded conductor has white insulation.
- 2) *Power grounding*: Power grounding is intended to carry low frequency or dc fault currents back to fuses or other protective devices. This is primarily a current consideration. Connection occurs via the system-grounding electrode. The grounding conductor is bare or has green insulation.
- 3) *Bonding*: Bonding provides a common equipment ground to prevent potential differences that may shock an individual or flash over and cause a fire. This is primarily a voltage consideration. Proper bonding can be obtained by connecting all metal equipment together and to a single point of reference.
- 4) *Shielding*: Shielding is used to prevent electromagnetic noise from interfering with the shielded signal. This is primarily a frequency-related consideration. Shielding is accomplished by isolation of the signal wires from sources of noise using a Faraday shield.
- 5) *Transient Protection*: Transient protection is intended to provide a path to dissipate high-energy signals into the soil. This is primarily an energy consideration. Proper transient protection is realized by creating an equal potential grid under the area. The

EFFECTIVE DATA
QUALITY AND
GROUNDING
DESIGNS
CONSIDER THE
NEUTRAL, POWER
GROUNDING,
BONDING,
SHIELDING, AND
TRANSIENT
PROTECTION.

transient protection ground is connected to a separate electrode system from the power ground; however, all systems must eventually be bonded together [2].

Application

The initial ground requirement is for the electrical power system. This ground connection is made at the point that electrical supply is provided to the location. Communications circuits consisting of hardwired, metallic conductors require a ground also at the initial point of service. Data systems use the ground as a common reference. Electromagnetic interference (EMI) and radio-frequency interference (RFI) shielding require a reference for isolation. The ground provides a convenient, common point.

Grounding requirements of each of these earthing systems are quite different. Nevertheless, to prevent potential differences between any of the circuits, bonding must be made between all ground systems. The arrangement of the bonds must be designed to limit ground loops and other paths that may introduce external problems into a network.

Oftentimes, grounds in a facility are implemented with little design effort. In improperly designed or installed facilities, circulating currents and ground loops can exist, and create interference with telecommunications, data, and computer networks.

One of the challenges of proper design results from the fact that systems that are most susceptible to grounding problems are often the ones that are the cause of power quality problems. Computer systems are frequently the most susceptible to damage from power system disruption or to interference on high-speed communications networks. Additionally, the numerous personal computers, media devices, and uninterruptible power supplies (UPS) in a facility all have switched mode power supplies (SMPS). These nonlinear devices may create harmonics and noise on the neutral resulting in poor power quality and overheating [7], [8].

To alleviate some of this impact, the preferred SMPS devices have a 12-pulse rectifier system to lower harmonic impact. The reduced bandwidth of ripple created by a 12-pulse system makes it easier to mitigate the fundamental and higher harmonics in the supplied power [9]. A proper grounding system will solve many of these problems. In some more severe instances, an isolation transformer or filters must be employed. With properly designed filter and grounding, current ripple as low as $30E^{-6}$ has been obtained [9].

The noise created by the numerous switched mode supplies creates transients that can compromise the integrity of insulation for some materials such as mineral insulation cable.

The National Electrical Code

The initial reference for any electrical installation must be the National Electrical Code (NEC). Its objective is specifically stated in the very first article.

The purpose of this *Code* is the practical safeguarding of persons and property from hazards arising from the use of electricity. This *Code* contains provisions that are considered necessary for safety . . . [2]

In addition, NEC Article 250 contains over 25 pages that are specifically associated with grounding. Numerous other articles address issues such as neutrals, transient protection, and details for specific facilities and installations. Although the NEC is not a design specification, it does provide significant material to consider. The NEC, then, should be a minimum standard for any installation.

One area of grounding must be enhanced beyond the code requirements. Ground path resistance is critical for safety and effective reduction of interference. Trying to accommodate all soil conditions, the NEC allows a ground resistance of up to 25 Ω for electrical power installations [2]. This is inadequate for communications, data, and safety purposes. According to the *IEEE Green Book*, Section 4 “There is no implication that 25 ohm, per se, is a satisfactory level for a grounding system [4].”

Consider that a 120-V circuit with a 25- Ω ground connection will have a fault current of less than 5 A.

$$125 \text{ V}/25 \Omega = 4.8 \text{ A.} \quad (1)$$

A standard, 20-A breaker will not trip at that level of fault current. Further, consider that hazardous electrical shock can occur at any level above 6 mA. Instantaneous death can be caused by 100 mA [10]. Therefore, anyone who inadvertently comes into the area of a fault is susceptible to being shocked.

For safety considerations, the ground path must be less than 5 Ω [4]. This will ensure that the supply breaker sees enough ground-fault current to trip if the wire is in direct contact with ground.

$$125 \text{ V}/5 \Omega = 25 \text{ A.} \quad (2)$$

A good ground resistance reference for electronic circuits can be obtained from the standards for intrinsically safe shunt diode barriers. In these systems, ground resistance from the furthest barrier cannot exceed 1 Ω . This requirement is incorporated into the NEC by reference to ANSI RP 12.6-1995 [2], [11], [12]. The low ground resistance allows objectionable energy, including harmonics, generated by the device to be dissipated safely into the earth.

FOR DATA
SYSTEMS,
ADDITIONAL
ENHANCEMENTS
ARE REQUIRED
TO REDUCE
GROUND
RESISTANCE
BELOW 1 Ω .

Reference Ground

Interconnection of grounding systems is critical to the integrity of the electrical network. The very first criterion is to establish a reference point for all the grounds, bonding, and shielding for the facility. Some practitioners refer to this as a single point ground. *It is more appropriately a reference point for numerous grounding systems.*

A proper reference point begins with a driven copper ground rod outside the building. Test the ground resistance. If, because of soil conditions, ground resistance is not less than 1 Ω , it will be necessary to design additional components.

A 1- Ω ground resistance is achievable in good soil, or with enhanced grounding systems. If contact resistance of greater than 1 Ω is obtained after installation, additional improve-

ments will be required to create an acceptable quality ground [3], [5], [13].

In larger facilities, such as industrial or even large commercial installations, it is often necessary for the reference ground to be a ring or grid under and around the entire facility. The construction and design details of this type of reference ground installation have been extensively covered in previous publications [3], [5], [6], [13].

The reference point must be accessible for convenient checking of the quality of the various grounding systems. Because of the number of items that will be connected to this location, it is beneficial to install a bus bar. To ensure integrity of the ground, the bus must be insulated from other metal. At least 11 different systems must be bonded back to this point by an appropriate path [12], [14], [15].

- 1) building structural steel
- 2) electrical enclosure grounding conductor
- 3) common point from the transformer wye
- 4) neutral grounded conductor at the main disconnect
- 5) transient protection
- 6) telephone reference ground
- 7) data (dc) power supply common
- 8) back-up battery supply (UPS)
- 9) shielding
- 10) isolated (ac) power circuits
- 11) network equipotential reference ground.

The list itself reveals the complexity of the problem for grounding design and installation at any facility, and illustrates why effective grounding is such a specialty within electrical engineering.

Many of these systems have unique grounding points; however, each system must be bonded together in order to reduce potential differences. Moreover, the design of the interconnection (bonding) must be configured to reduce circulating currents and other common sources of problems for communications and networks.

Although a facility has a connection to earth, the full ground path must be positively identified. Because of the

circulating current problems already referenced, it is important to locate any inadvertent connection to earth and isolate redundant paths.

Other than the electrical enclosure grounding conductor, all the ground, bond, and common conductors must be insulated from building steel or enclosures, in order to prevent shorting of the ground paths. To assure a positive bond and reduce loosening, connections must be crimped and bolted or must use exothermic welding. If the isolated grounds are run in conduit, the raceway must be nonconductive to eliminate the necessity of bonding the ground to steel conduit [16].

One common, but inappropriate practice is to use the building steel as the grounding electrode conductor. It is appropriate to use the reinforcing bar in the building foundation as a portion of the grounding electrode, when installed correctly during construction [13]. It is also necessary to bond the building steel to the reference ground. It is neither effective nor appropriate, however, to use the building steel as part of the grounding circuit.

Of additional importance is size of the conductors to the reference ground point. The maximum fault current on the circuit is the starting point. This is used to select wire size based on resistance. However, the frequency of the transients also can become a very critical issue. The inductive reactance of the circuit increases dramatically with the frequency. As a result, the length of the conductor and number of bends are often contributing factors in the choice of conductor size [15].

When verifying ties to the reference ground, ensure that every metallic conduit has a good electrical connection to its electrical panel. If there is not a good link in an existing facility, install a bonding strap between the conduit and the enclosure.

Finally, nonelectric metallic equipment that is near electrical enclosures must be bonded to the reference

WITH CONSISTENT DESIGN, INSTALLATION, AND MAINTENANCE OF THE GROUNDING SYSTEM, NOISE DISTURBANCES CAN BE CONTROLLED.

ground. Run a bond wire from any electrical enclosure to any other metal pipe or equipment that is within 5 ft horizontally or 8 ft vertically. The wire must be mechanically protected but should not be run in conduit [2].

Neutral

The neutral is a white or gray current carrying conductor that is intentionally connected to ground. The neutral must be bonded to ground in the main service entrance panel. This ground should have a continuous path from the main service panel to the reference ground point. As illustrated in Figure 1, this is the only point that the neutral may be connected to earth in the entire facility.

A new neutral point is created at each transformer secondary. This is considered to be a new source. The neutral is connected to earth at each new source, as shown in Figure 1. A

grounding electrode conductor connects this point to the reference ground.

At all other disconnects and breaker boxes derived from this source, isolate the neutral terminals from the grounding terminals. It may be necessary to remove the bonding screw or a jumper. This applies to every electrical distribution panel in the building. If the derived connections have been erroneously made, part of the neutral current will energize the grounding conductor back to the transformers, causing ground loops and safety issues.

Modifications to an existing power system may be enhanced by performing a harmonic analysis. High levels of harmonic distortion may increase the necessary size of the neutral [17]. This may necessitate creating new electrical feeders for the different neutrals. Harmonics may also require the addition of filters or isolation transformers. This topic is extensive enough that several papers have been published inside the IEEE and PCIC on this item alone [7].

Isolated Earth Ground

In mixed-use facilities, much of the noise on a communication or data system is introduced from the system ground. This noise exists on the ground circuit primarily because of switched electronics (SMPSs) and system imbalances. In these cases, it is necessary to construct an "isolated" earth ground for data and communication systems. This is commonly referred to as an isolated triad earth grounding system.

A triad system consists of three driven copper ground rods. These ground rods are bonded together underground using uninsulated copper wire. To ensure a solid, long-term connection, connect the wires to the ground rod by exothermic welding.

The ground rods should be laid out in a triangle configuration, with spacing between rods of at least 2.2 times

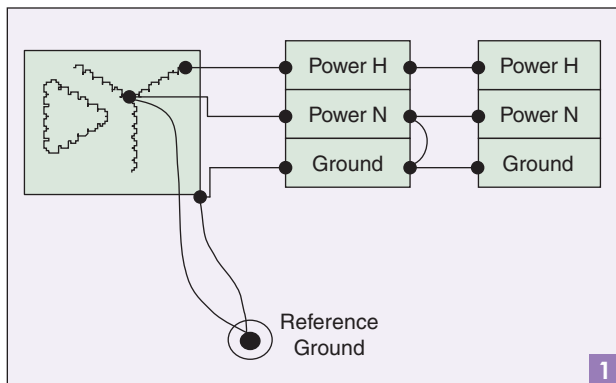

Neutral.

the length of the rods [3]. The net resistance for n rods, R_n , is determined from the resistance of one rod R . This assumes the rods are spaced apart by the distance of 2.2 times the length.

$$R_n = [R/n]^* [2 - e^{-.17(n-1)}]. \quad (3)$$

This represents the decay in the capacitance associated with propagation in the earth and is based on the contact resistance as determined by Dwight's Formula [18].

In order to maintain isolation of the triad ground, at least a 5-ft separation from any other grounding elements, such as fences and pipe, is necessary [2].

For connection to the protected equipment, run an isolated ground conductor from one of the triad corners to the data equipment room. This should be a continuous run of insulated, stranded conductor, with no splices. Repeat from another corner with another isolated ground conductor to the network equipment room. This should follow a different path to reduce common interference [19]. The ring bus connection to the triad ground is shown in Figure 2.

Although this ground system is isolated, it is still necessary to bond it to the power reference ground for safety reasons [2], [11]. Connect the third corner of the triad to the reference point ground bus for the building. If there is interference, the NEC permits this connection to be removed.

All the wire must be routed so bends have at least an 8-in radius arc. Keep the runs as straight as possible. Minimize the number of bends and turns. This will reduce the inductance and resulting high-frequency impedance of the ground path.

Tinned copper wire in the ground should be avoided. Over time, the tinning may be leached, increasing the ground resistance of the system. Special consideration must be given to steel ground rods in order to avoid interaction with copper grounds, which would form a copper-zinc battery. A transition clamp consisting of bronze or stainless steel should be used to buffer copper-to-steel connections. A better choice is to exothermically weld all connections between steel and copper.

Rack and Cable Tray

To deal with communications and data requirements, special racks that contain computers and high-speed communications equipment are often installed. Grounding these racks requires supplemental consideration that is very different from 60-Hz electrical power equipment grounds. The grounding system for this equipment must be

appropriately isolated from all other equipment in the facility. There are three types of electrical connections that must be separately addressed: the ac power, the cable tray, and the building metal.

For a star designed ground system, install an insulated bus bar as a single point ground for the room. For a very basic installation, the bus bar is simply one isolated, insulated terminal that is visible and can be readily checked.

Bring at least two isolated ground conductors from the isolated triad ground to the network room. These should follow different routes. For rooms with a single point bus, connect both grounds to the single point. For rooms with a ring bus, connect to opposite sides of the ring.

Cable tray is often used for dc power and communications cable; ac power cables should not be run in the same tray as dc power and communications circuits because of noise induced from the ac to the dc circuits. The tray must be constructed so the sections are

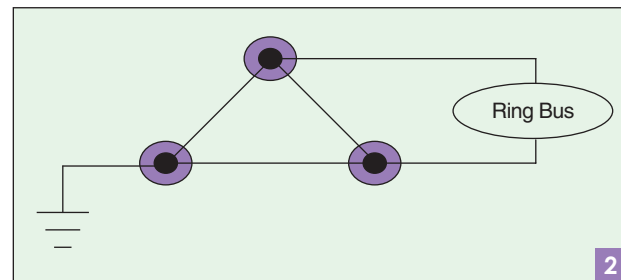

Isolated ground conductors for triad.

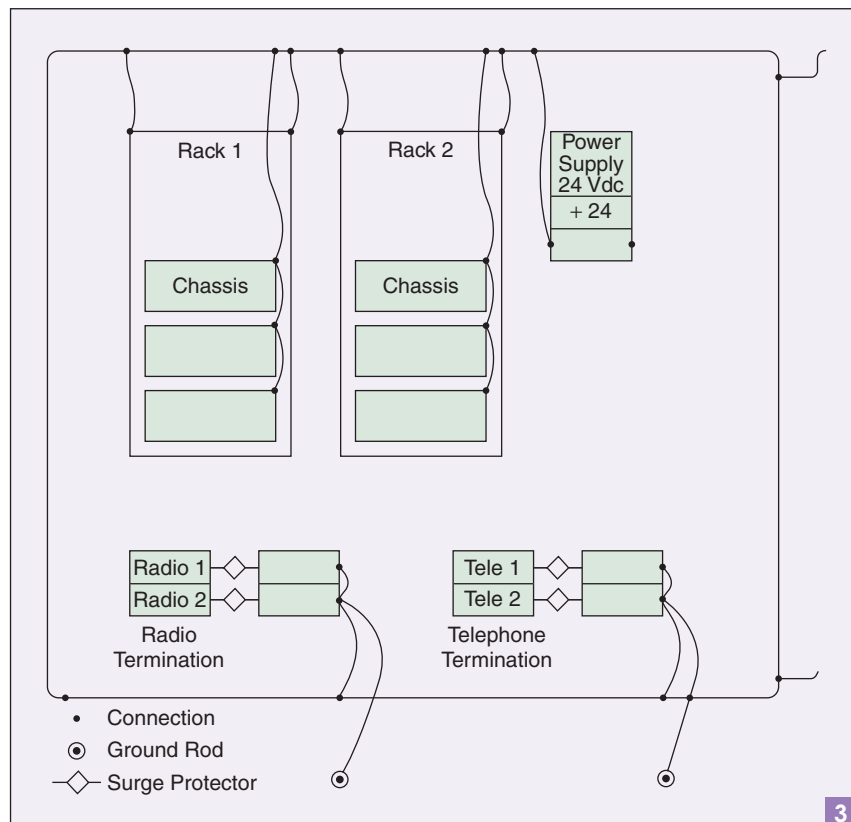

Rack bonding.

electrically continuous. If the mounting hardware does not provide an adequate path, bonding jumpers must be connected between the sections.

For a more robust ground system, a rat race ring for the room can be constructed similar to Figure 3. The rat race ring is simply a localized version of the overall building or facility ground ring. The preferred design is an isolated, insulated grounding conductor that completely encircles the room. Connect the rat race to an isolated triad ground in at least two separate locations. When there is only one rack of equipment and a single cable, a single conductor can be placed on the cable tray in lieu of a complete rat-race ring. Run a conductor down each tray and bond it to the main rat race ring.

Connect from the ground conductor in the tray to each rack at two separate locations. On one end, fix the conductor to the connector. Remove any paint from the rack where the connection will be made on the other end. Use a bolt, washer, and nut to anchor the connector to the rack.

Each chassis mounted to the rack must be bonded to the ground system. A copper grounding strip can be run down both sides of the rack. This is placed over the mounting hole and behind the mounting flange of the device. Alternately place a grounding jumper from the chassis to the rack. If loose mounted equipment is placed on a shelf in the rack, the equipment should be bonded exactly as a chassis.

Every grounding joint on the tray must be made with crimp connectors, to assure a positive tie. The conductors and connections must be reinsulated to prevent inadvertent bonding and resultant ground loops. The ground wire must never be allowed to touch any metal except at the terminal connection. Inadvertent bonding can result in ground loops with multiple current paths which negate voltage control.

THE MOST EFFECTIVE WAY TO ELIMINATE NOISE FROM COMPUTER NETWORKS AND DATA SYSTEMS IS TO COMPLETELY ISOLATE THE POWER AND GROUNDING FROM OTHER ELECTRICAL DISTURBANCE.

Network Isolated Power

The most effective way to eliminate noise from computer networks and data systems is to completely isolate the power and grounding from other electrical disturbance. Although this section is not always required, it must be considered in critical installations.

All electrical components of the grounding network system must be isolated from contact with any other metal surface, including building steel and other electrical devices.

A shielded isolation transformer creates a new power system and isolates the network from interference, odd harmonics from equipment, and from ground loops on the existing power system. A 1:1 dry type transformer installed upstream of the network power panel provides this new isolated power system as shown in Figure 4. Size the transformer for the total network load anticipated in the racks.

The input power supply can come from circuit breakers in the existing power panel. The power supply

ground connection must be made with PVC conduit or cable tray. Do not connect the building power ground to this transformer. Connect a conductor from the frame to the isolated earth ground bus.

Install a new electrical distribution panel for the network equipment. The panel should be installed on an insulated sheet of nonconductive material.

Connect an appropriately sized grounding conductor between the distribution panel and the isolated ground bus for the network. Create a new neutral by bonding the transformer neutral terminal block to the ground.

Install receptacles needed for the network within the equipment rack. This isolates the receptacles from possible contact with other conductive surfaces. Placing the receptacles in the cabinets also removes trip hazards from cords on the floor. Connect the receptacles to the new isolated electrical distribution panel. Any equipment

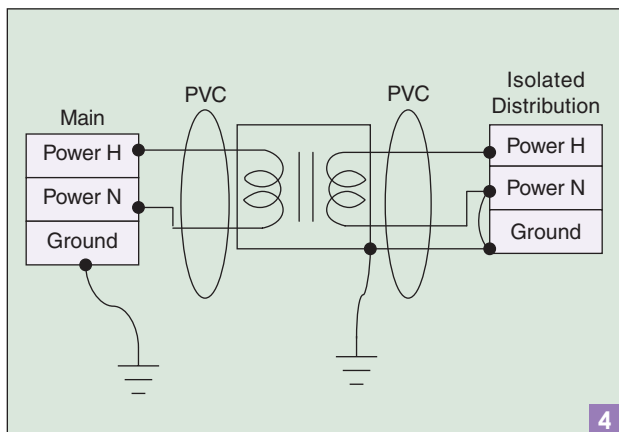

Isolation of grounding and new power system.

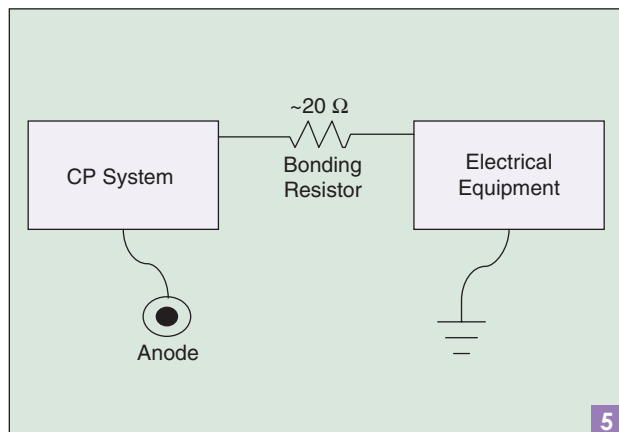

Sketch of CP bonding resistor.

used with the network, including UPS, must be powered from the network receptacles. This is imperative to prevent injection of foreign noise into the system.

Install transient voltage surge suppressors on the isolated power system. This can be at the distribution panel. Use the isolated earth ground for the grounding conductor [3].

Cathodic Protection

In some areas, the metallic structures or underground piping have cathodic protection (CP). Metallic structures in contact with the earth often are a low resistance path to ground. However, the electrical system ground cannot be connected directly to the cathodically protected metal. A tie from the protected metal directly to the neutral would short the cathodic protection system and render it ineffective. For this reason metals that have cathodic protection must be isolated from the electric system ground.

If it becomes necessary to bond cathodically protected equipment to other electrical equipment [2], a controlled design system can be used. To prevent inadvertent shorting, a bonding resistor can be used between the protected equipment and the electric system ground. A typical cathodic protection circuit has a resistance to ground on the order of 2 Ω . The bonding resistor should be an order of magnitude greater, or on the order of 20 Ω .

However, the resistor prevents the system from being effectively bonded during transient conditions. Consider the voltage drop created by a fault of 10,000 A.

$$V = 10,000 \text{ A} * 20 \Omega = 200 \text{ kV.} \quad (4)$$

Nevertheless, this is more effective than an open circuit.

Figure 5 shows a typical bond between a CP system and the power system ground.

A cathodic protection system has inherent personnel protection. Equipment properly connected to a CP system has a very low resistance path to ground (<2 Ω). This provides an adequate path for dissipation of any current in a fault condition.

Conclusions

An effective data quality and grounding design considers the neutral, power grounding, bonding, shielding, and transient protection. The NEC is the beginning consideration, but it must be enhanced to provide a safe grounding resistance less than 5 Ω . For data systems, additional enhancements are required to reduce ground resistance below 1 Ω .

A reference ground is necessary for interconnection of at least 11 different ground systems: structural, enclosures, wye, neutral, transient, telephone, data, battery, shielding, isolated, and equipotential.

Special considerations are required for configuring the nondata elements of networks and communications because of the mix of analog and digital signals. The three major components are grounding enclosure, creating an

equipotential earth ground, and considering an isolated electrical supply.

With consistent design, installation, and maintenance of the grounding system, noise disturbances can be controlled.

Acknowledgments

Special thanks go to Wayne Ashley, Gene Fagan, Dusty Brown, and Rich Hulett for their excellent contributions during the review process. Their comments provided invaluable insights into the comprehension of the paper and stimulated the authors into additional research.

References

- [1] *Standard for Electrical Safety Requirements for Employee Workplace*, NFPA 70E, 1996.
- [2] *National Electrical Code*, NFPA 70, 2002.
- [3] M.O. Durham and R. Durham, "Lightning, grounding, and protection for control systems," *IEEE Trans. Ind. Applicat.*, vol. 31, pp. 45-54, Jan./Feb. 1995.
- [4] *Recommended Practice for Grounding of Industrial and Commercial Power Systems (The IEEE Green Book)*, IEEE 142-1991.
- [5] M.O. Durham and R.A. Durham, "Ground system design considerations for vessels," *IEEE Ind. Appl. Mag.*, vol. 7, Nov./Dec. 2001.
- [6] M.O. Durham and R. Durham, "Grounding system design for isolated locations and plant systems," in *Proc. IEEE PCIC Conf.*, Denver, CO, Sep. 1995.
- [7] M.O. Durham, R.D. Strattan, and D. Carter, "Harmonic impact on power system design," *Int. J. Power and Energy Syst.*, no. 203-1012, Feb. 1994.
- [8] *Recommended Practice for Powering and Grounding Electronic Equipment (The IEEE Emerald Book)*, IEEE 1100-1992.
- [9] M. Fathizadeh, "Analysis and design of a high-current, high-voltage accurate power supply for the advanced photon source storage ring," in *Proc. 1993 IEEE Particle Acceleration Conf.*, Washington, DC, May 1993.
- [10] C.F. Dalziel and W.R. Lee, "Reevaluation of lethal electric current," *IEEE Trans. Ind. and General Applicat.*, vol. 4, pp. 467-476, Sep./Oct. 1968.
- [11] *Canadian Electrical Code*, CSA Std C22.1:2002.
- [12] *Wiring Practices for Hazardous (Classified) Locations Instrumentation Part 1: Intrinsic Safety*, ANSI/ISA RP 12.6-1995.
- [13] E.J. Fagan and R.H. Lee, "The use of concrete enclosed reinforcing rods as grounding electrodes," *IEEE Trans. Ind. General Applicat.*, vol. 6, pp. 337-348, Jul./Aug. 1970.
- [14] M.O. Durham, R.A. Durham, and K.D. Durham, "TVSS Designs," *IEEE Ind. Appl. Mag.*, vol. 8, pp. 31-36, Sep./Oct. 2002.
- [15] *Standard for the Installation of Lightning Protection Systems*, NFPA 780, 2000.
- [16] R.H. Kaufmann, "Some fundamentals of equipment-grounding circuit design," *AIEE Trans. (Applications and Industry)*, vol. 73, pp. 227-232, Nov. 1954.
- [17] *Recommended Practice for Electric Power Distribution for Industrial Plants (The IEEE Red Book)*, IEEE 141-1993.
- [18] H.B. Dwight, "Calculation of resistances to ground," *AIEE Trans.*, pp. 1319-1328, Dec. 1936.
- [19] *IEEE Recommended Practices and Requirements for Harmonic Control in Electrical Power Systems*, IEEE 519-1992.

Marcus O. Durham (mod@ieee.org) is with THEWAY Corp and the University of Tulsa, in Tulsa, Oklahoma. Robert A. Durham is with D2 Technologies, Inc. in Broken Arrow, Oklahoma. Marcus Durham is a Fellow of the IEEE, and Robert Durham is a Member of the IEEE. This article first appeared in its original form at the 2004 IEEE/IAS Petroleum and Chemical Industry Technical Conference.